

# Domopac Bunded



## *The solution for poor commercial water pressure*

- Non-corrosive holding tank (WRAS approved material)
- Pre-fitted WRAS approved fill valve
- Protective lid enclosure as standard
- Minimal installation required
- Adjustable digital display flow controller
- Dry run protection with auto restart (time delay)

The Domopac Bunded is designed for commercial use where there is low mains water pressure and where pressure fluctuates. Every Domopac Bunded tank benefits from a 'tank within a tank' bundled construction, with the outer tank able to maintain a minimum of 110% of the volume of the inner tank. The inner tank acts as the primary storage container, whilst the outer tank acts as a fail safe in the event of a spill.

It is electronically controlled through a flow switch unit which starts and stops the pump automatically when a tap is opened and closed. The Domopac Bunded is designed for areas where the floor space is not restricted.

# Domopac Bunded

## Options

| Model                        |
|------------------------------|
| 250ltr Bunded Fixed Speed    |
| 250ltr Bunded Variable Speed |
| 650ltr Bunded Fixed Speed    |
| 650ltr Bunded Variable Speed |

## System connections

| Connection | Size   |
|------------|--------|
| Inlet      | ½" BSP |
| Outlet     | 1" BSP |
| Overflow   | 1" BSP |
| Drain Off  | 1" BSP |

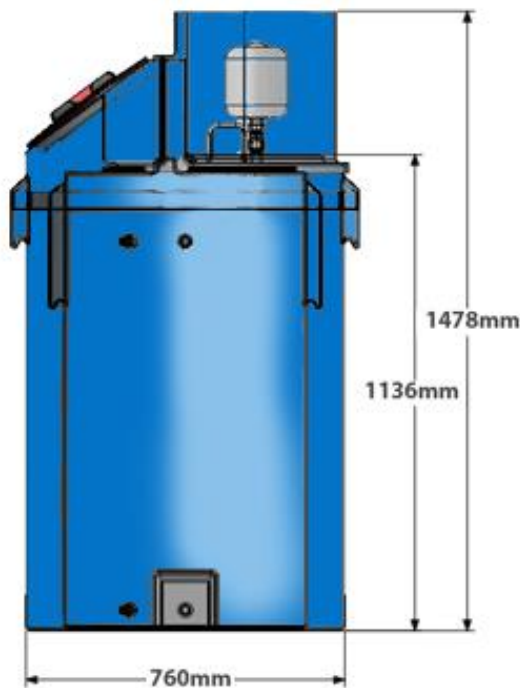

250ltr Bunded



650ltr Bunded

|                   | Fixed speed option   | Variable speed option  |
|-------------------|--|--|
| Power supply      | 240 volt, 50Hz   | 240 volt, 50Hz   |
| Controller        | Presflo Multi with integral 3 litre pressure vessel              | Steadypres M/T 07 supplied with 8ltr pressure vessel             |
| Current Input     | 3.4 amp  | 4 amp  |
| Mains Power Cable | 2 mtr x 1mm <sup>2</sup> 3 core fitted with 5 amp fuse main plug | 2 mtr x 1mm <sup>2</sup> 3 core fitted with 5 amp fuse main plug |
| Tank Weight Empty | 250ltr = 49kg   650ltr = 94kg                                    | 250ltr = 55kg   650ltr = 100kg                                   |
| Tank Weight Full  | 1ltr = 1 kg plus weight of empty tank                            | 1ltr = 1 kg plus weight of empty tank                            |
| Access Cover Ø    | Internal 190mm, External 285mm                                   | Internal 190mm, External 285mm                                   |

| Pump option    | Power |      | Q l/min  | 0  | 10 | 20 | 30 | 40 | 50 | 60 | 70   | 80 |
|----------------|-------|------|----------|----|----|----|----|----|----|----|------|----|
|                | kW    | HP   |          |    |    |    |    |    |    |    |      |    |
| Fixed speed    | 0.55  | 0.75 | H Metres | 42 | 40 | 38 | 34 | 30 | 24 | 18 | 11.5 | 5  |
| Variable speed | 0.75  | 1    | H Metres | 63 | 61 | 59 | 57 | 54 | 50 | 45 | 39   | 31 |