

Domoboost Trio 10-6 2 1/2" 1 Phase Two Pump Booster Set Data Sheet



Booster Set Specification

Operation Mode:	Duty/Standby or Duty/Assist
Supply Voltage:	230v~1ph~50hz
Pumps:	2 off 2.2 Kw horizontal multistage centrifugal pumps manufactured from Aisi 304 stainless steel F.L.C. per pump =9.6 Amps
Suction Manifold:	Aisi 304 Stainless Steel – BSP (M) connection
Discharge Manifold:	Aisi 304 Stainless Steel – BSP (M) connection
Suction Valve:	Brass Isolating Ball/NRV combination valve to pump suction
Discharge Valve:	Brass Isolating Ball/NRV combination valve to pump suction
Control:	2 no discharge mounted variable speed drive complete with LCD display to indicate system overview and operating parameters such as pressure, speed, frequency and power absorbed. Complete with automatic changeover of duty pump, volt free contacts for remote alarm and provision for wiring of low level float switch. Option to run pumps in fixed speed mode from 0 – 50hz
BMS Contacts:	Yes (common)
Low Water Level Contacts:	Yes
Vessels:	2 no 8 litres Anti Cycle Vessel fitted to discharge manifold. (5 Year Guarantee)
Base Frame:	Galvanised Steel

Dimensional Drawing

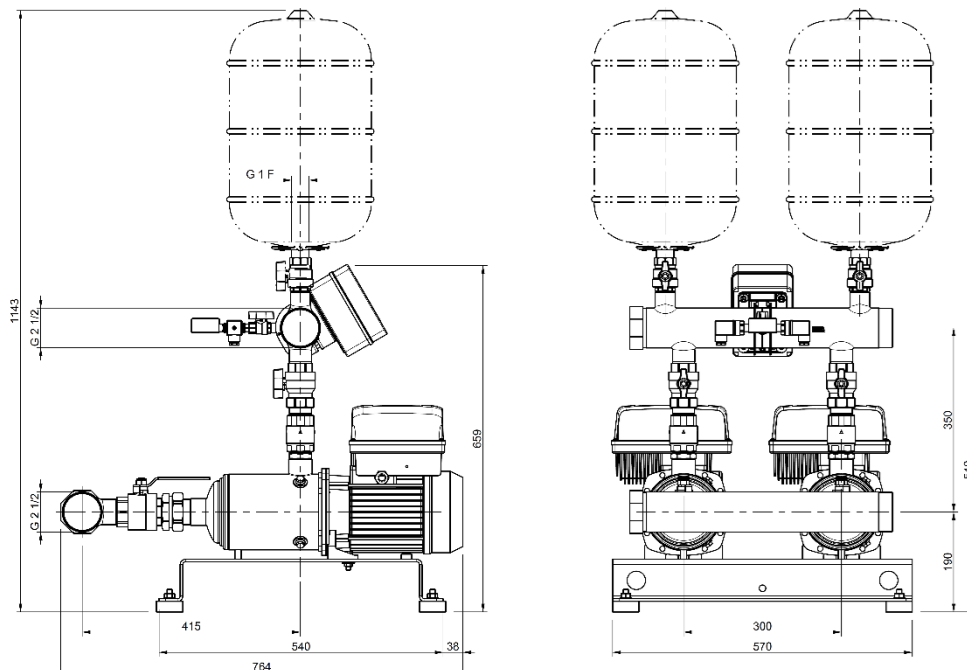

Pump Curve

Requested data

1	Flow	l/min	0
2	Head	m	0
3	Geodetic head	m	0

Pump

Operating Flow	l/min		Frequency	Hz	50
Operating Head	m		Number of poles		2
Impeller Diameter	Designed mm	101	Speed		rpm

Test standard: ISO 9906:2012 - Grade3B

Water, clean [100%]; 20°C; 998.3kg/m³; 1mm²/s

